



HiPace® 300 for TCP 350, DN 100 ISO-K

PFEIFFER 

HiPace® 300

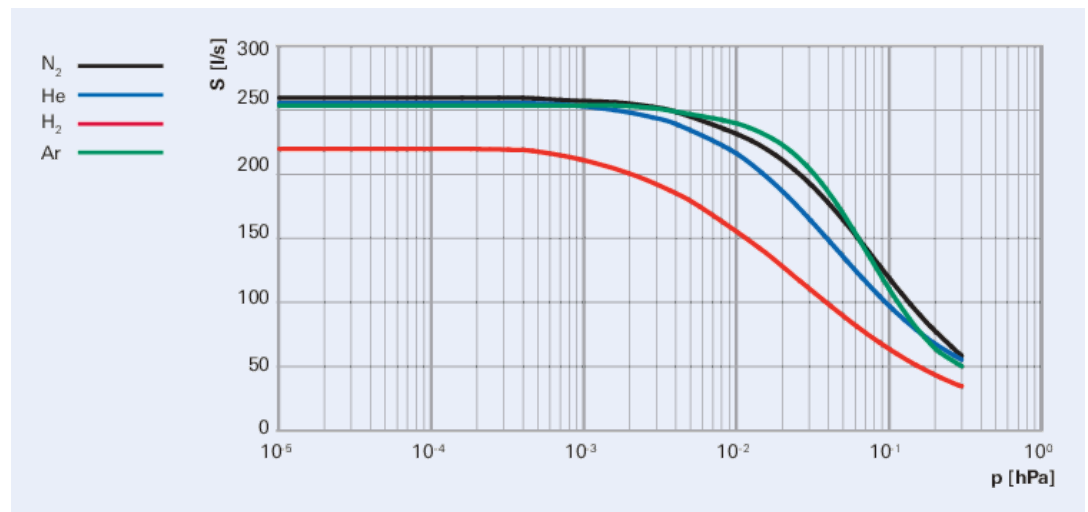

Illustration only

HiPace® 300 for TCP 350, DN 100 ISO-K

- Rugged, powerful turbopump with a pumping speed of up to 260 l/s for N₂
- For external TCP 350 drive electronics
- For installation in any orientation
- Ideal for applications that require separate installation of pump and drive
- Extensive accessories expand the range of applications

Characteristics



HiPace® 300

Dimensions

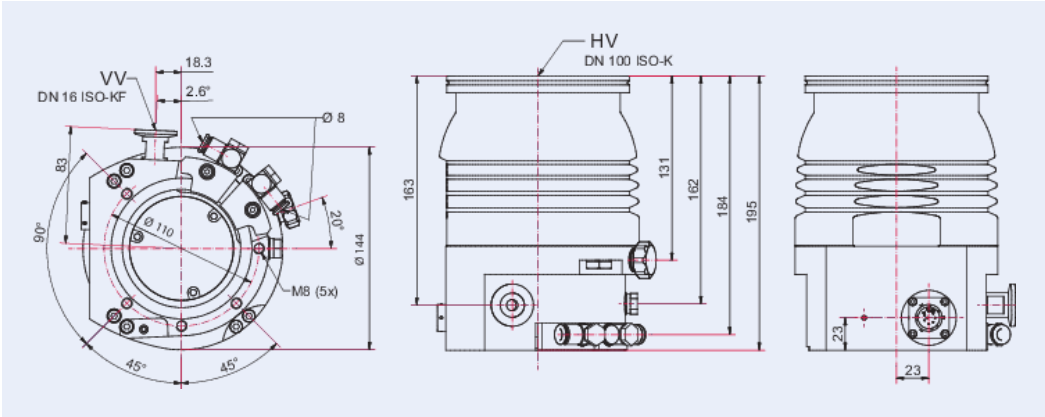

HiPace® 300

Technical Data	HiPace® 300 for TCP 350, DN 100 ISO-K
Electronic drive unit	TCP 350
Type of electronic drive unit installation	External electronic drive unit -not incl.-
Position of power supply pack	External power supply pack
Cooling method	Water
Pumping speed	792 – 936 m ³ /h
Pumping speed category	1080 m ³ /h
Pumping speed for He	255 l/s
Pumping speed for N ₂	260 l/s
Vacuum range min	1 · 10 ⁻⁷ hPa
Vacuum range max	1 · 10 ⁻⁷ hPa
Cooling water temperature	15 – 35 °C
Venting connection	G 1/8"
Bearing	Hybrid
Cooling method, optional	Air (forced convection)
Mounting orientation	Arbitrary
Pumping speed for Ar	255 l/s
Pumping speed for H ₂	220 l/s
Emission sound pressure level (EN ISO 2151)	≤50 dB(A)
Gas throughput at final rotation speed for H ₂	14 hPa·l/s
Gas throughput at final rotation speed for He	11 hPa·l/s
Run-up time	2.5 min
Compression ratio for Ar	1 · 10 ¹¹
Compression ratio for H ₂	9 · 10 ⁵
Compression ratio for He	1 · 10 ⁸
Compression ratio for N ₂	1 · 10 ¹¹
Gas throughput at final rotation speed for N ₂	7 hPa·l/s
Gas throughput at final rotation speed for Ar	4 hPa·l/s
Fore-vacuum max. for N ₂	17 hPa 12.75 Torr 17 mbar
Pumping speed for He	255 l/s
Pumping speed for N ₂	260 l/s
Rotation speed ±2 %	60,000 rpm 60,000 min ⁻¹
Pumping speed for Ar	255 l/s
Pumping speed for H ₂	220 l/s
Compression ratio for N ₂	1 · 10 ¹¹
Compression ratio for H ₂	9 · 10 ⁵

HiPace® 300

Compression ratio for He	1 · 10 ⁸
Compression ratio for Ar	1 · 10 ¹¹
Permissible radial magnetic field max.	5.5 mT
Fore-vacuum max. for N ₂	17 hPa
Cooling water flow	50 l/h
03 Vacuum range	High Vacuum Ultra-high Vacuum
Connection flange	DN 100 ISO-K / DN 16 ISO-KF G 1/4" Thread
Rotation speed variable	35 – 100 %
Rotation speed ± 2 %	60,000 rpm
Weight	5.8 kg
Connection flange (in)	DN 100 ISO-K
Connection flange (out)	DN 16 ISO-KF G ¼"

Order number	HiPace® 300 for TCP 350, DN 100 ISO-K
HiPace® 300 for TCP 350, DN 100 ISO-K	PM P03 993 C

Accessories	HiPace® 300 for TCP 350, DN 100 ISO-K
Operating fluid reservoir for HiPace 300	PM 143 451 AT
Spare parts package 1, bearing for HiPace 300	PM E11 051 -T



Errors and/or changes excepted. - 9/30/2025

Are you looking for an optimum vacuum solution?

**Talk to us:
Pfeiffer Vacuum GmbH
Germany
T +49 6441 802-0**

Or scan the barcode, to visit our web page:



<https://webportal.pfeiffer-vacuum.com/global/en/contact>

**Follow Us On Social Media
#pfeiffervacuum**



www.pfeiffer-vacuum.com

PFEIFFER 